

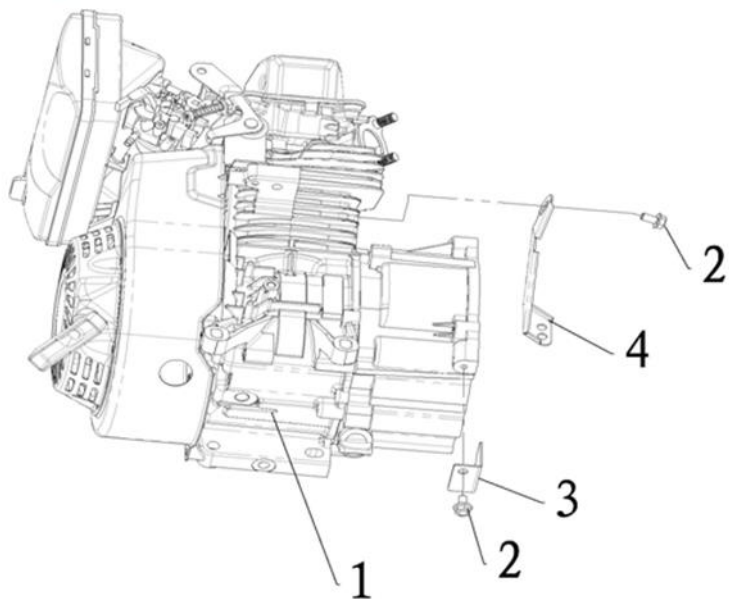

GENERADOR DGR 3200 REF: DGR363200



P1

PAG	POS	REFERENCIA	DESCRIPCION	CANT
P1	1	DGR363200M	DGR363200M MOTOR DGR 3200	1
P1	2	DGR362500/P1/2	DGR362500/P1/2 TORNILLO M6X12 DGR 2500/3200	4
P1	3	DGR362500/P1/3	DGR362500/P1/3 SOPORTE TRASERO DGR 2500/3200	1
P1	4	DGR362500/P1/4	DGR362500/P1/4 SOPORTE ANCLAJE FILTRO AIRE DGR 2500/3200	4

VERSION 1.0



GENERADOR DGR 3200 REF: DGR363200

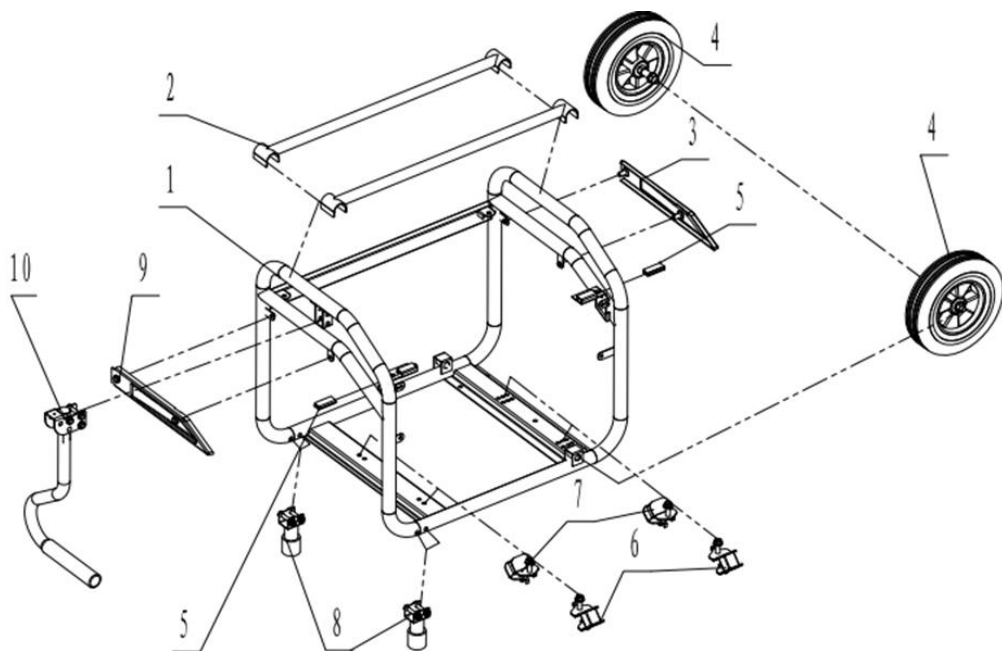

P2

PAG	POS	REFERENCIA	DESCRIPCION	CANT
P2	1	DGR362500/P2/1	CHASIS DGR 2500/3200	1
P2	2	-----	BARRA HORIZONTAL TRANSPORTE	2
P2	3	-----	DESPICE PAGINA 3	1
P2	4	-----	DESPICE PAGINA 4	2
P2	5	DGR362500/P2/5	GOMA DEPOSITO DGR 2500/3200	2
P2	6	-----	DESPICE PAGINA 5	2
P2	7	-----	DESPICE PAGINA 6	2
P2	8	-----	DESPICE PAGINA 7	2
P2	9	-----	DESPICE PAGINA 8	1
P2	10	-----	DESPICE PAGINA 9	1

VERSION 1.0



GENERADOR DGR 3200 REF: DGR363200

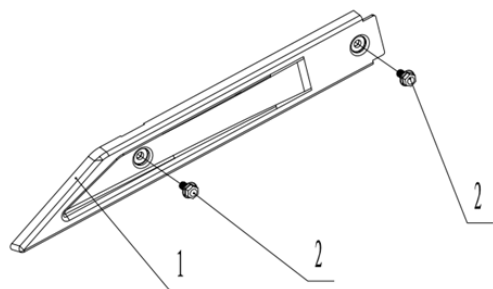

P3

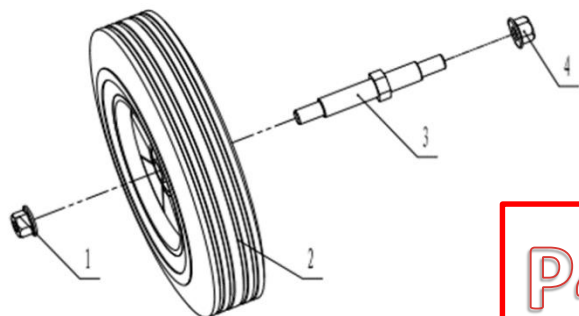

P4

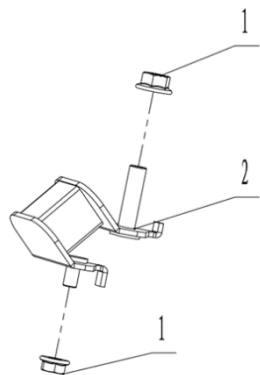

P5

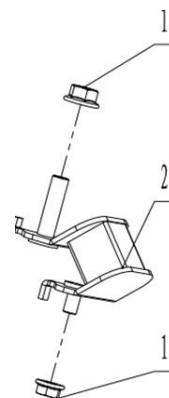

P6

PAG	POS	REFERENCIA	DESCRIPCION	CANT
P3	1	DGR362500/P3/1	TAPA DERECHA DGR 2500/3200	1
P3	2	DGR362500/P3/2	TORNILLO M6X12 DGR 2500/3200	2
P4	1	DGR362500/P4/1	TUERCA M12 DGR 2500/3200	2
P4	2	DGR362500/P4/2	RUEDA DGR 2500/3200	2
P4	3	DGR362500/P4/3	EJE RUEDA DGR 2500/3200	2
P4	4	DGR362500/P4/4	TUERCA M10 DGR 2500/3200	2
P5	1	DGR362500/P5/1	TUERCA M8 DGR 2500/3200	4
P5	2	DGR362500/P5/2	SILENTBLOCK B DGR 2500/3200	2
P6	1	DGR362500/P6/1	TUERCA M8 DGR 2500/3200	4
P6	2	DGR362500/P6/2	SILENTBLOCK A DGR 2500/3200	2



GENERADOR DGR 3200 REF: DGR363200

P7

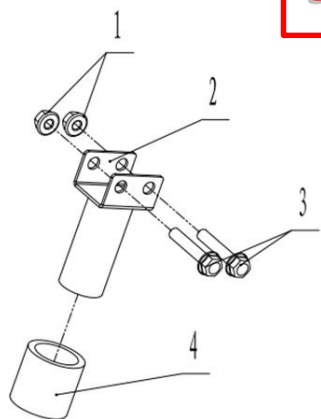

PAG	POS	REFERENCIA	DESCRIPCION	CANT
P7	1	DGR362500/P5/1	TAPA DERECHA DGR 2500/3200	1
P7	2	DGR362500/P7/2	TORNILLO M6X12 DGR 2500/3200	2
P7	1	DGR362500/P7/3	TUERCA M12 DGR 2500/3200	2
P7	2	DGR362500/P7/4	RUEDA DGR 2500/3200	2
P8	1	DGR362500/P8/1	TORNILLO M6X12 DGR 2500/3200	2
P8	2	DGR362500/P8/2	TAPA IZQUIERDA DGR 2500/3200	2
P9	1	DGR362500/P9/2	ASA COMPLETA DGR 2500-7000	1

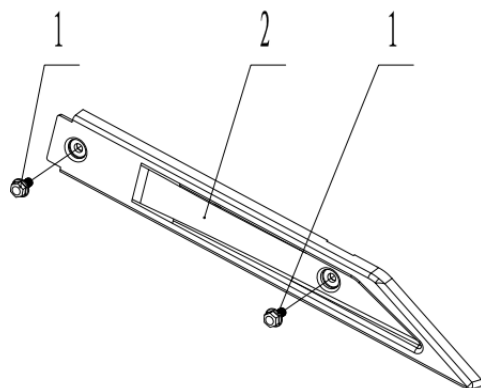
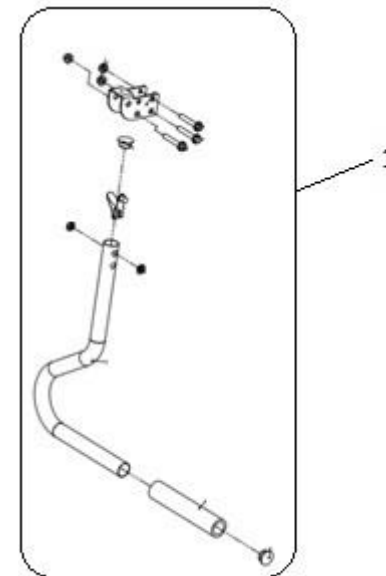

P8

P9



GENERADOR DGR 3200 REF: DGR363200

P10

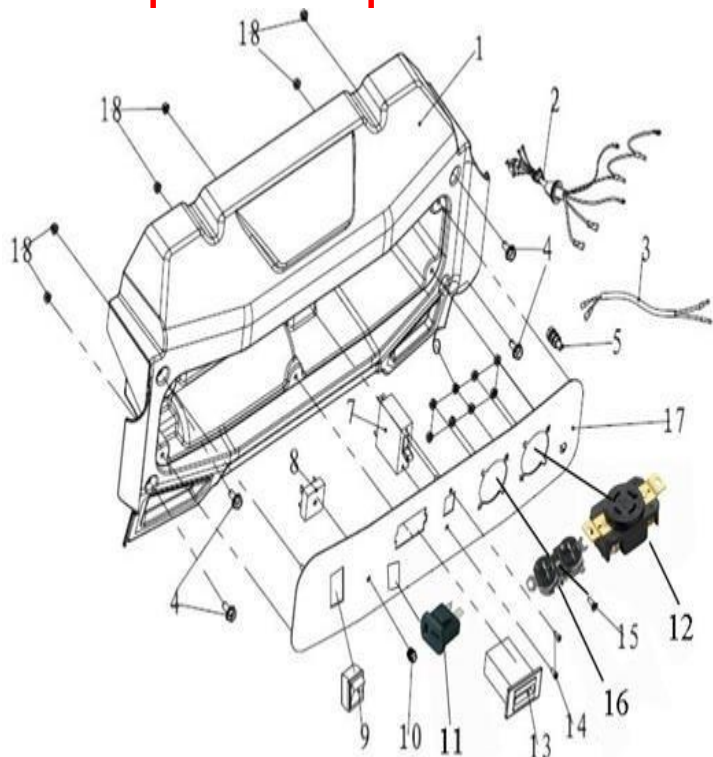

PAG	POS	REFERENCIA	DESCRIPCION	CANT
P10	1	DGR362500/P10/1	TAPA PANEL DGR 2500/3200	1
P10	2	DGR362500/P10/2	MAZO CABLE ALTERNADOR DGR 2500/3200	1
P10	3	DGR362500/P10/3	CABLE PANEL DGR 2500/3200	1
P10	4	DGR362500/P10/4	TORNILLO M6X12 DGR 2500/3200	4
P10	5	DGR362500/P10/5	TORNILLO TOMA TIERRA DGR 2500/3200	1
P10	6	DGR362500/P10/6	TUERCA M4 DGR 2500/3200	8
P10	7	DGR363200/P10/7	DIFERENCIAL DGR 3200	1
P10	8	DGR362500/P10/8	RECTIFICADOR DGR 2500/3200	1
P10	9	DGR362500/P10/9	INTERRUPTOR ON/OFF DGR 2500/3200	1
P10	10	DGR362500/P10/10	LED ALARMA ACEITE DGR 2500/3200	1
P10	11	DGR361300S/P3/11	ENCHUFE T DC DGR MULTIVOLTAJE	1
P10	12	DGR361300S/P3/12	TOMA DOBLE DGR MULTIVOLTAJE	1
P10	13	DGR362500/P10/13	PANTALLA DIGITAL DGR 2500/3200	1
P10	14	DGR362500/P10/14	TORNILLO M3X6 DGR 2500/3200	2
P10	15	DGR362500/P10/15	TORNILLO M4X10 DGR 2500/3200	8
P10	16	DGRT365500S/P11/16	TOMA 4 AGUJEROS DGR	2
P10	17	DGR363200S/P10/17	PANEL DGR 3200 MULTIVOLTAJE	1
P10	18	DGR362500/P10/18	TUERCA M4 DGR 2500/3200	6

VERSION 1.0



GENERADOR DGR 3200 REF: DGR363200

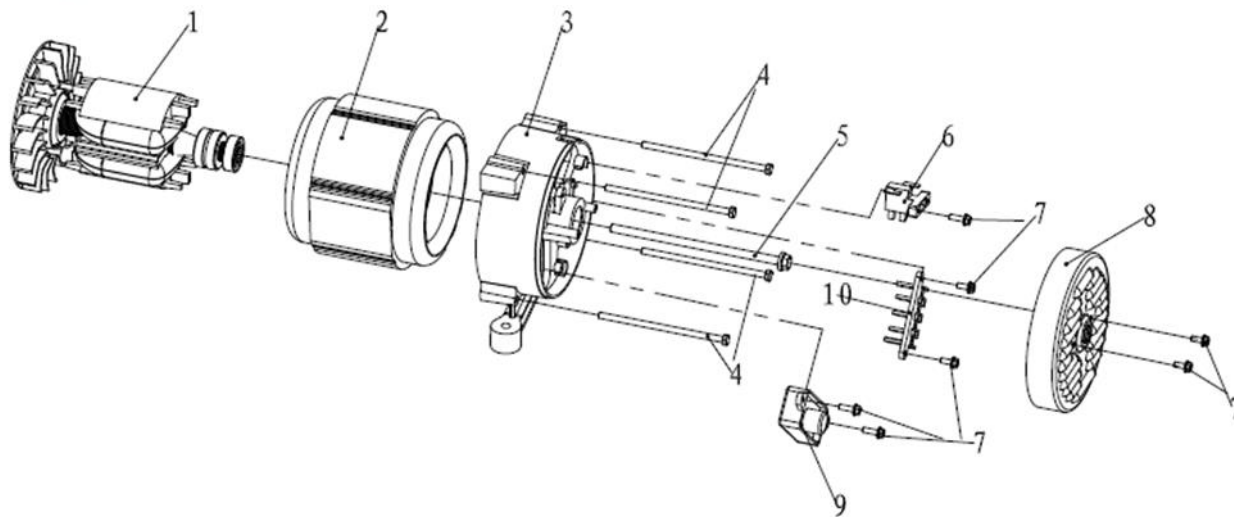

P11

PAG	POS	REFERENCIA	DESCRIPCION	CANT
P11	1	DGR363200S/P11/1	ROTOR 110/220V DGR 3200 MULTIVOLTAJE	1
P11	2	DGR363200S/P11/2	ESTATOR 110/220V DGR 3200 MULTIVOLTAJE	1
P11	3	DGR362500/P11/3	CIERRE ALTERNADOR DGR 2500/3200	1
P11	4	DGR363200/P11/4	TORNILLO M6X130 DGR 3200	4
P11	5	DGR363200/P11/5	TORNILO M8X1X180 DGR 3200	1
P11	6	DGR362500/P11/6	ESCOBILLAS DGR 2500/3200	1
P11	7	DGR362500/P11/7	TORNILLO M5X12 DGR 2500/3200	7
P11	8	DGR362500/P11/8	TAPA ALTERNADOR DGR 2500/3200	1
P11	9	DGR362500/P11/9	AVR DGR 2500/3200	1
P11	10	DGR362500/P11/10	PLACA CONEXIONES DGR 2500/3200	1

VERSION 1.0



GENERADOR DGR 3200 REF: DGR363200

P12

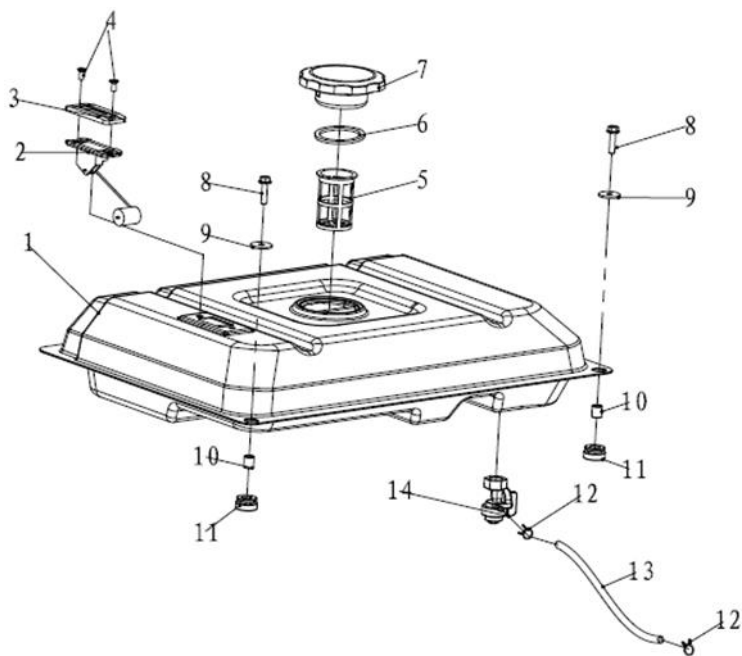

PAG	POS	REFERENCIA	DESCRIPCION	CANT
P12	1	DGR362500/P12/1	DEPOSITO COMPLETO DGR 2500/3200	1
P12	2	DGR362500/P12/2	AFORADOR DGR 2500/3200	1
P12	3	DGR362500/P12/3	TAPA AFORADOR DGR 2500/3200	1
P12	4	DGR362500/P12/4	TORNILLO M5X12 DGR 2500/3200	2
P12	5	DGR362500/P12/5	FILTRO DE LLENADO DGR 2500/3200	1
P12	6	DGR362500/P12/6	JUNTA TAPON DGR 2500/3200	1
P12	7	DGR362500/P12/7	TAPON DEPOSITO DGR 2500/3200	1
P12	8	DGR362500/P12/8	TORNILLO M6X25 DGR 2500/3200	2
P12	9	DGR362500/P12/9	ARANDELA ANCHA DGR 2500/3200	2
P12	10	DGR362500/P12/10	CAQUILLO DGR 2500/3200	2
P12	11	DGR362500/P12/11	GOMA DEPOSITO DGR 2500/3200	2
P12	12	DGR362500/P12/12	CLIP TUBO DGR 2500/3200	2
P12	13	DGR362500/P12/13	TUBO GASOLINA DGR 2500/3200	1
P12	14	DGR362500/P12/14	GRIFO GASOLINA DGR 2500/3200	1

VERSION 1.0



GENERADOR DGR 3200 REF: DGR363200

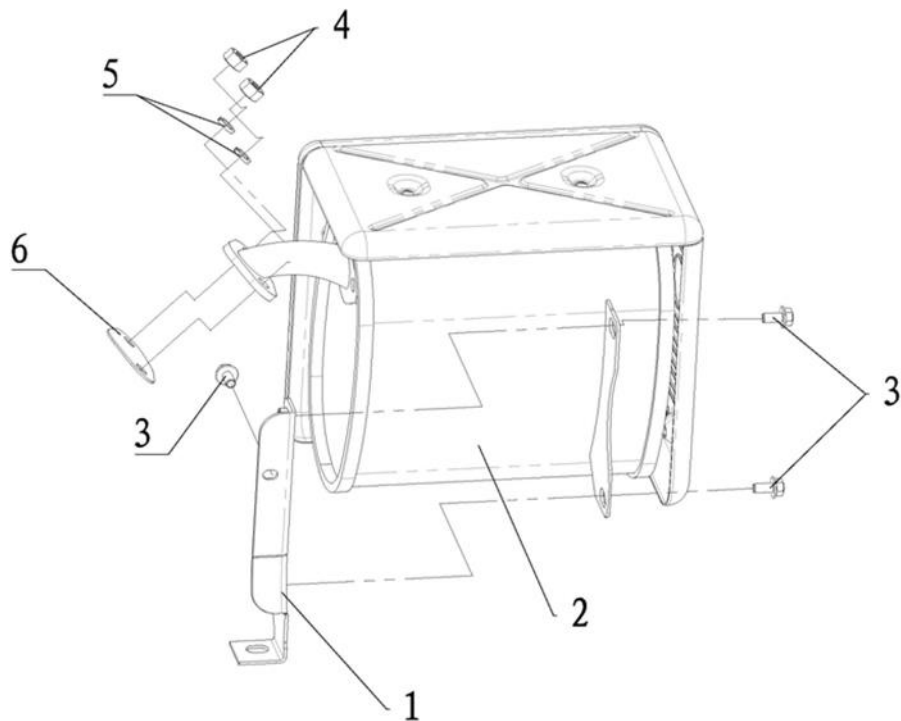

P13

PAG	POS	REFERENCIA	DESCRIPCION	CANT
P13	1	DGR362500/P13/1	SOPORTE SILENCIOSO DGR 2500/3200	1
P13	2	DGR363200/P13/2	SILENCIOSO DGR 3200	1
P13	3	DGR362500/P13/3	TORNILLO M6X12 DGR 2500/3200	1
P13	4	DGR362500/P13/4	TUERCA M8 DGR 2500/3200	3
P13	5	DGR362500/P13/5	ARANDELA ELASTICA 8 DGR 2500/3200	2
P13	6	DGR362500/P13/6	JUNTA DGR 2500/3200	2

VERSION 1.0



MOTOR DGR 3200 REF: DGR363200M

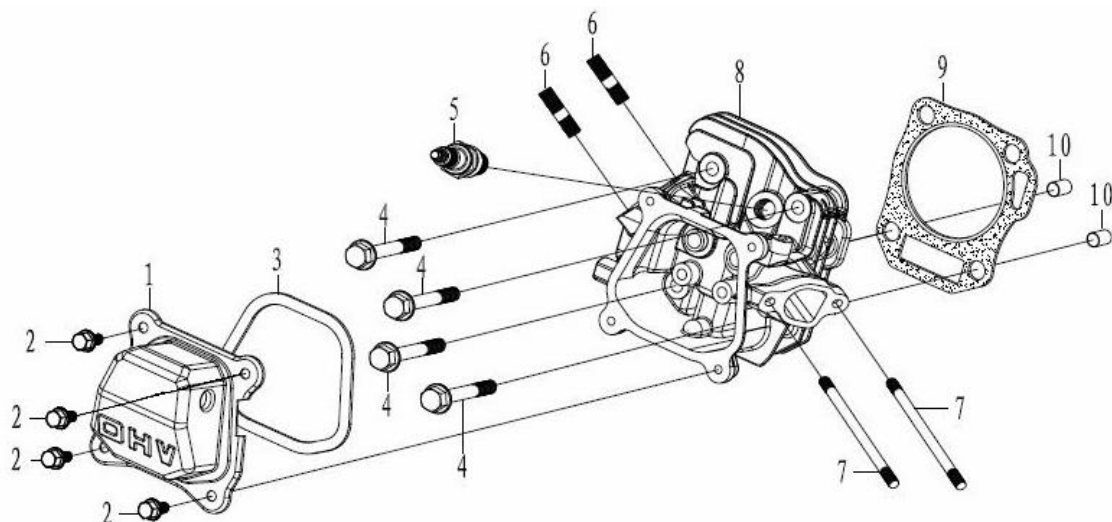

P1

PAG	POS	REFERENCIA	DESCRIPCION
P1	1	DGR362500M/P1/1	TAPA VALVULAS DGR2500/3200
P1	2	DGR362500M/P1/2	TORNILLO TAPA VALVULAS DGR2500/3200
P1	3	DGR362500M/P1/3	JUNTA TAPA VALVULAS DGR2500/3200
P1	4	DGR362500M/P1/4	TORNILLO CULATA DGR2500/3200
P1	5	DGR362500M/P1/5	BUJIA DGR2500/3200
P1	6	DGR362500M/P1/6	ESPARRAGO ESCAPE DGR2500/3200
P1	7	DGR362500M/P1/7	ESPARRAGO CARBURADOR DGR2500/3200
P1	8	DGR363200M/P1/8	CULATA DGR3200
P1	9	DGR363200M/P1/9	JUNTA CULATA DGR3200
P1	10	DGR362500M/P1/10	CASQUILLO CULATA DGR2500/3200

VERSION 1.0



MOTOR DGR 3200 REF: DGR363200M

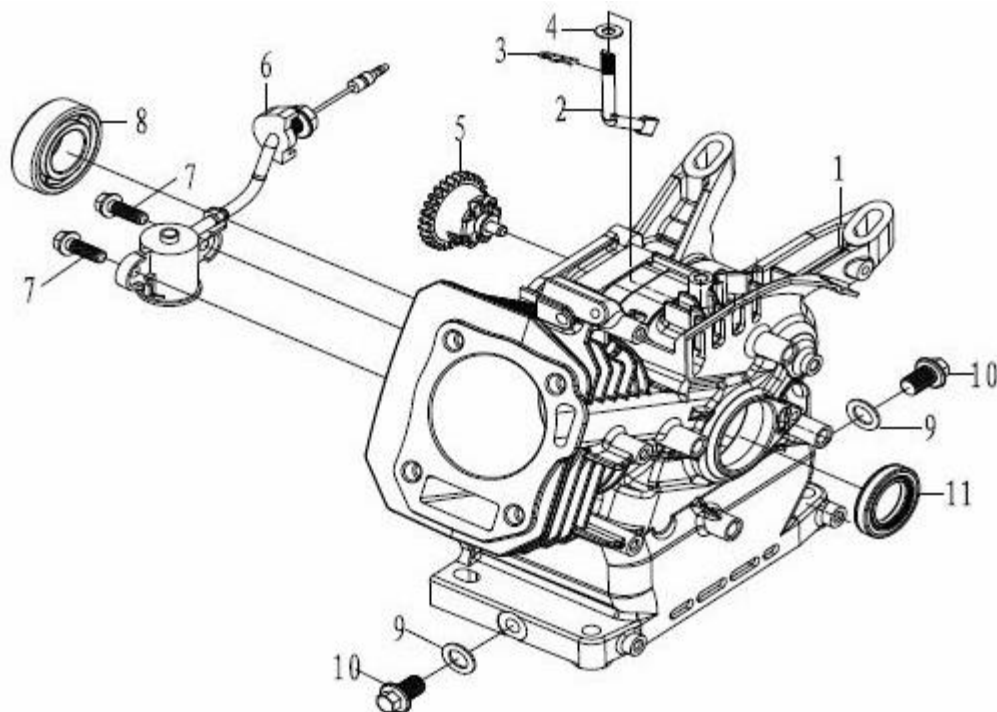

P2

PAG	POS	REFERENCIA	DESCRIPCION
P2	1	DGR363200M/P2/1	CILINDRO DGR3200
P2	2	DGR362500M/P2/2	EJE REGULADOR DGR2500/3200
P2	3	DGR362500M/P2/3	PASADOR REGULADOR DGR2500/3200
P2	4	DGR362500M/P2/4	ARANDELA REGULADOR DGR2500/3200
P2	5	DGR362500M/P2/5	REGULADOR COMPLETO DGR2500/3200
P2	6	DGR362500M/P2/6	ALARMA ACEITE DGR2500/3200
P2	7	DGR362500M/P2/7	TORNILLO M6X16 DGR2500/3200
P2	8	DGR362500M/P2/8	RODAMIENTO CIGÜÑAL DGR2500/3200
P2	9	DGR362500M/P2/9	ARANDELA DGR2500/3200
P2	10	DGR362500M/P2/10	TORNILLO VACIADO CARTER DGR2500/3200
P2	11	DGR362500M/P2/11	ARANDELA VACIADO DGR2500/3200

VERSION 1.0



MOTOR DGR 3200 REF: DGR363200M

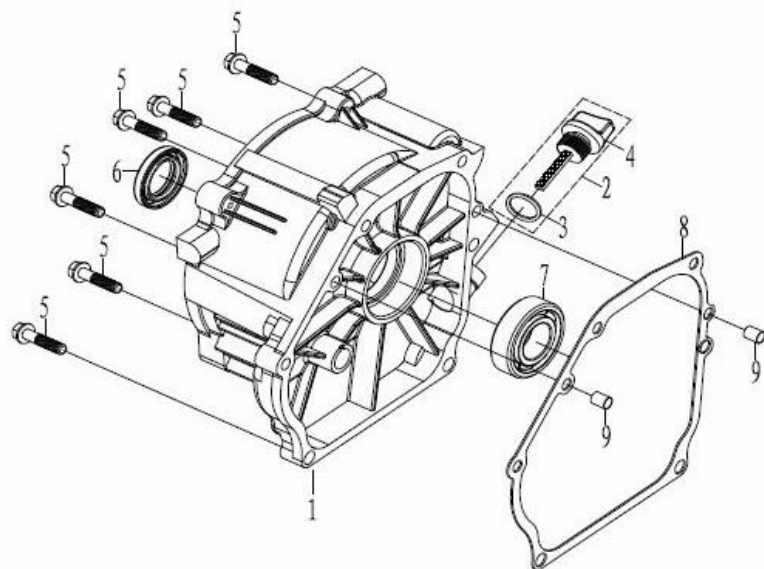

P3

PAG	POS	REFERENCIA	DESCRIPCION
P3	1	DGR362500M/P3/1	TAPA CARTER DGR2500/3200
P3	2	DGR362500M/P3/2	TAPON NIVEL COMPLETO DGR2500/3200
P3	3	DGR362500M/P3/3	TORNILLO CARTER DGR2500/3200
P3	4	DGR362500M/P3/4	RETEN CIGÜÑAL DGR2500/3200
P3	5	DGR362500M/P3/5	RODAMIENTO CIGÜÑAL DGR2500/3200
P3	6	DGR362500M/P3/6	JUNTA CARTER DGR2500/3200
P3	7	DGR362500M/P3/7	CASQUILO CULATA DGR2500/3200

VERSION 1.0



MOTOR DGR 3200 REF: DGR363200M

P4

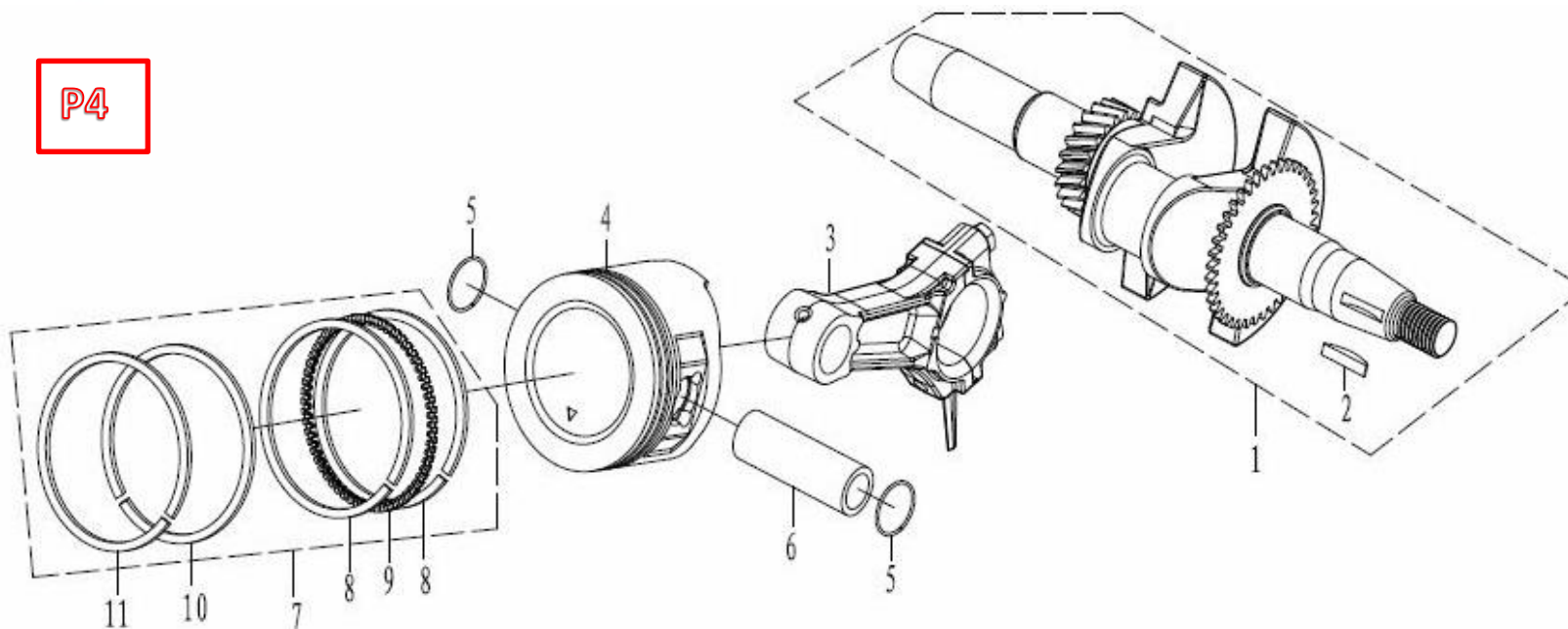

PAG	POS	REFERENCIA	DESCRIPCION
P4	1	DGR363200M/P4/1	CIGÜÑAL DDGR3200
P4	2	DGR362500M/P4/2	CHAVETA CIGÜÑAL DGR2500/3200
P4	3	DGR363200M/P4/3	BIELA DGR3200
P4	4	DGR363200M/P4/4	PISTON DGR3200
P4	5	DGR362500M/P4/5	GRUPILLA BULON DGR2500/3200
P4	6	DGR362500M/P4/6	BULON DGR2500/3200
P4	7	DGR363200M/P4/7	KIT SEGMENTO DGR3200

VERSION 1.0



MOTOR DGR 3200 REF: DGR363200M

P5

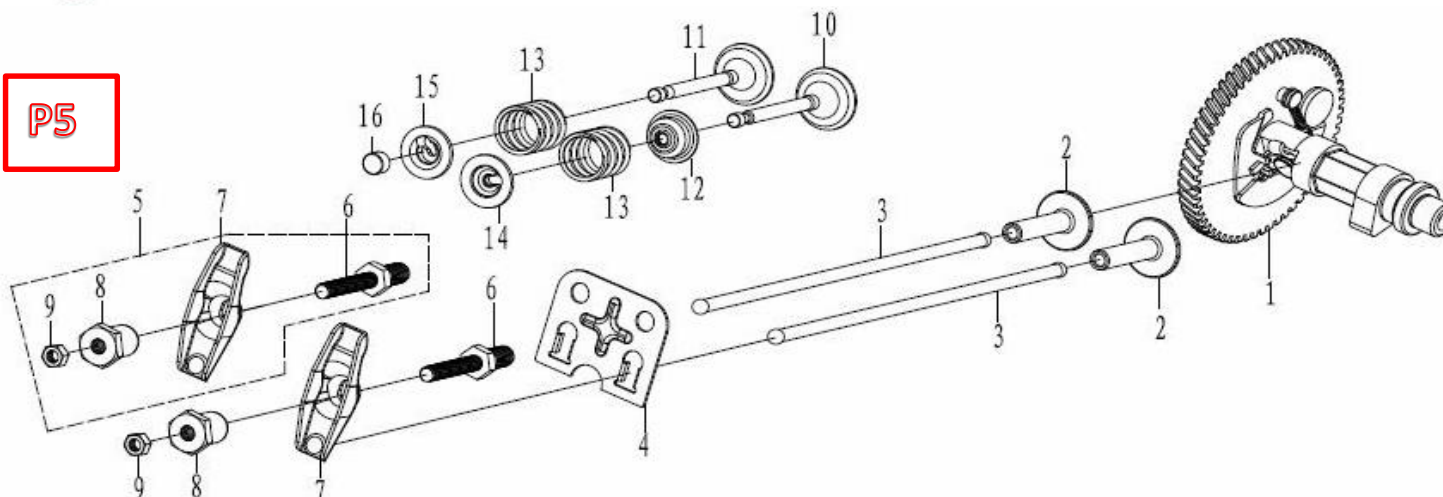

PAG	POS	REFERENCIA	DESCRIPCION
P5	1	DGR362500M/P5/1	ARBOL DE LEVAS DGR2500/3200
P5	2	DGR362500M/P5/2	TAQUE DGR2500/3200
P5	3	DGR362500M/P5/3	VARILLA EMPUJADORA DGR2500/3200
P5	4	DGR362500M/P5/4	CHAPA GUIA VARILLA DGR2500/3200
P5	5	DGR362500M/P5/5	KIT BALANCIN DGR2500/3200
P5	6	DGR362500M/P5/10	VALVULA ADMISION DGR2500/3200
P5	7	DGR363200M/P5/11	VALVULA ESCAPE DGR3200
P5	8	DGR362500M/P5/12	RETEN VALVULA ADMISION DGR2500/3200
P5	9	DGR362500M/P5/13	MUELLE VALVULA DGR2500/3200
P5	10	DGR362500M/P5/14	PLATILLO VALVULA ADMISION DGR2500/3200
P5	11	DGR362500M/P5/15	PLATILLO VALVULA ESCAPE DGR2500/3200
P5	12	DGR362500M/P5/16	CASQUILLO VALVULA DGR2500/3200

VERSION 1.0



MOTOR DGR 3200 REF: DGR363200M

P6

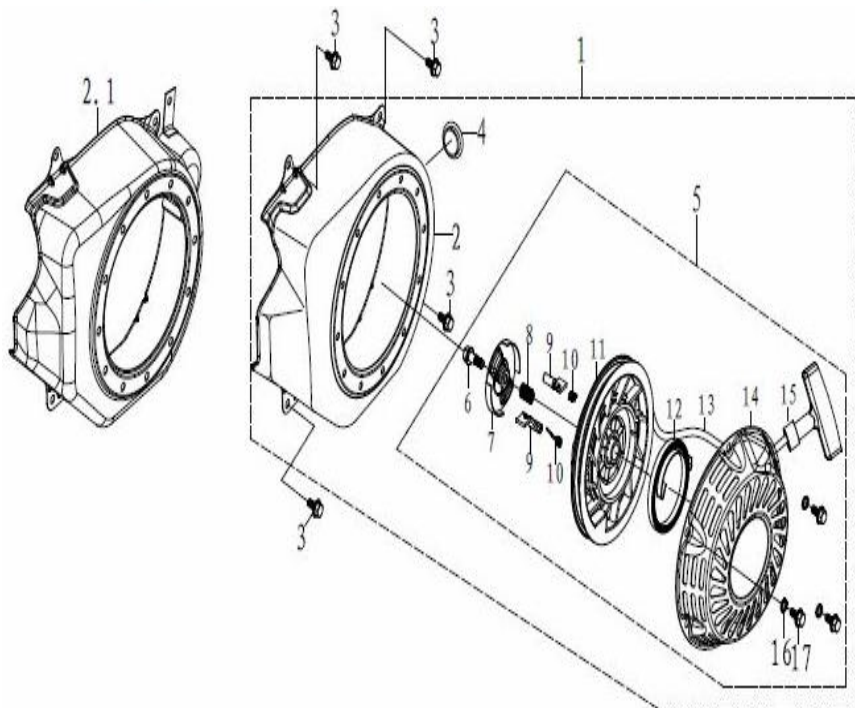

PAG	POS	REFERENCIA	DESCRIPCION
P6	2	DGR362500M/P6/2	CARCASA AIREACION DGR2500/3200
P6	3	DGR362500M/P6/3	TORNILLO CARCASA DGR2500/3200
P6	4	DGR362500M/P6/4	TAPON INTERRUPTOR DGR2500/3200
P6	5	DGR362500M/P6/5	ARRANCADOR COMPLETO DGR2500/3200
P6	6	DGR362500M/P6/6	TORNILLO CENTRAL ARRANCADOR DGR2500/3200
P6	7	DGR362500M/P6/7	CHAPA TRINQUETES DGR2500/3200
P6	8	DGR362500M/P6/8	RESORTE CENTRAL DGR2500/3200
P6	9	DGR362500M/P6/9	TRINQUETE DGR2500/3200
P6	10	DGR362500M/P6/10	RESORTE TRINQUETE DGR2500/3200
P6	11	DGR362500M/P6/11	POLEA ARRANCADOR DGR2500/3200
P6	12	DGR362500M/P6/12	MUELLE ARRANCADOR DGR2500/3200
P6	13	DGR362500M/P6/13	CUERDA ARRANCADOR DGR2500/3200
P6	14	DGR362500M/P6/14	CARCASA ARRACADOR DGR2500/3200
P6	15	DGR362500M/P6/15	POMO ARRANCADOR DGR2500/3200
P6	16	DGR362500M/P6/16	ARANDELA DGR2500/3200
P6	17	DGR362500M/P6/17	TORNILLO ARRANCADOR DGR2500/3200

VERSION 1.0



MOTOR DGR 3200 REF: DGR363200M

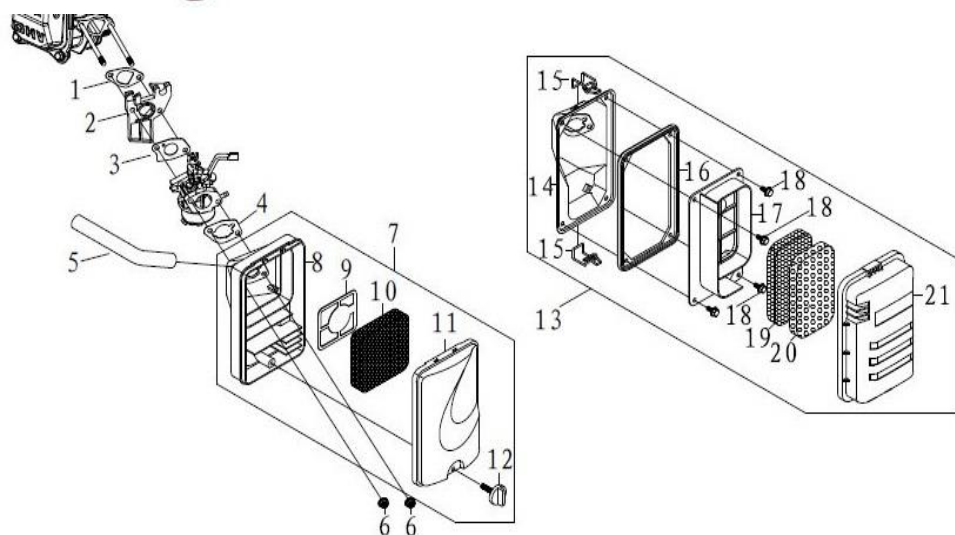

P7

PAG	POS	REFERENCIA	DESCRIPCION
P7	1	DGR362500M/P7/1	JUNTA ADMISION DGR2500/3200
P7	2	DGR362500M/P7/2	SEPARADOR TERMICO DGR2500/3200
P7	3	DGR362500M/P7/3	JUNTA CARBURADOR DGR2500/3200
P7	4	DGR362500M/P7/4	JUNTA FILTRO DE AIRE DGR2500/3200
P7	5	DGR362500M/P7/5	TUBO RESPIRADERO DGR2500/3200
P7	6	DGR362500M/P7/6	TUERCA CARBURADOR DGR2500/3200
P7	7	DGR362500M/P7/7	ANCALJE FILTRO AIRE COMPLETO DGR2500
P7	8	DGR362500M/P7/8	CARCASA FILTRO DE AIRE DGR2500
P7	9	DGR362500M/P7/9	REJILLA FILTRO DE AIRE DGR2500
P7	10	DGR362500M/P7/10	ELEMENTO FILTRO DE AIRE DGR2500
P7	11	DGR362500M/P7/11	TAPA FILTRO DE AIRE DGR2500
P7	12	DGR362500M/P7/12	TORNILLO PALOMILLA FILTRO DGR2500
P7	13	DGR363200M/P7/13	ANCLAJE FILTRO DE AIRE DGR 3200
P7	14	DGR363200M/P7/14	CARCASA FILTRO DE AIRE DGR 3200
P7	15	DGR363200M/P7/15	CIERRE FILTRO DE AIRE DGR 3200
P7	16	DGR363200M/P7/16	JUNTA FILTRO DE AIRE DGR 3200
P7	17	DGR363200M/P7/17	CARCASA INTERIOR FILTRO DGR 3200
P7	18	DGR363200M/P7/18	TORNILLO DGR 3200
P7	19	DGR363200M/P7/19	ELEMENTO FILTOR DE AIRE DGR 3200
P7	20	DGR363200M/P7/20	ELEMENTO FILTOR DE AIRE 2 DGR 3200
P7	21	DGR363200M/P7/21	TAPA FILTRO DE AIRE DGR 3200
P7	P8/1	DGR363200M/P8/1	CARBURADOR COMPLETO DGR3200

VERSION 1.0



MOTOR DGR 3200 REF: DGR363200M

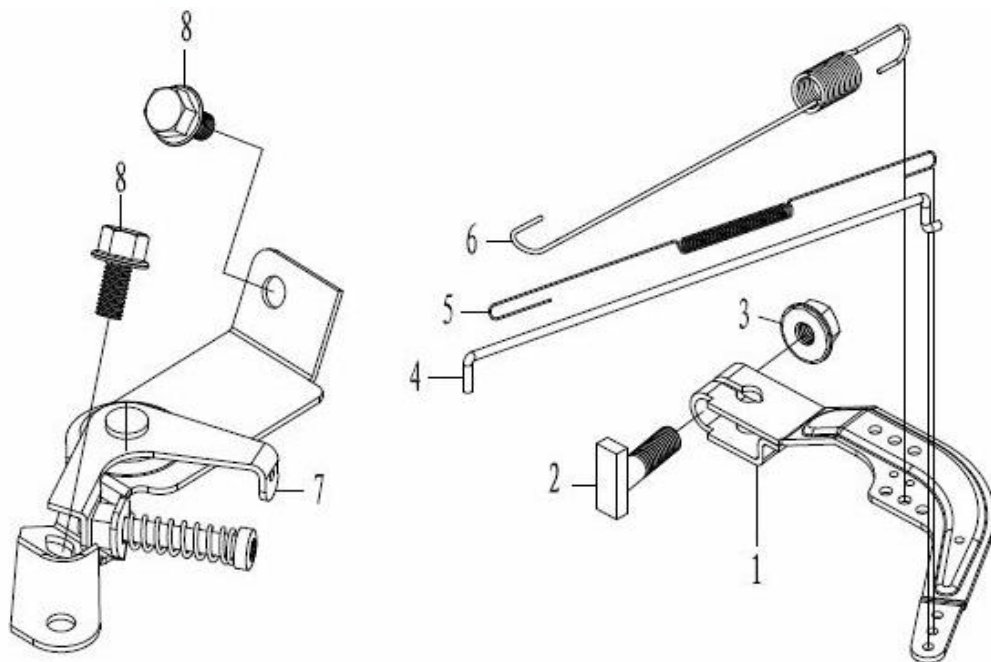

P9

PAG	POS	REFERENCIA	DESCRIPCION
P9	1	DGR362500M/P9/1	BRAZO REGULADOR DGR2500/3200
P9	2	DGR362500M/P9/2	TORNILLO REGUALDOR DGR2500/3200
P9	3	DGR362500M/P9/3	TUERCA REGULADOR DGR2500/3200
P9	4	DGR362500M/P9/4	VARILLA ACELERADOR DGR2500/3200
P9	5	DGR362500M/P9/5	MUELLE RETORNO ACELERADOR DGR2500/3200
P9	6	DGR363200M/P9/6	MUELLE REGULADOR DGR3200
P9	7	DGR362500M/P9/7	ACELERADOR COMPLETO DGR2500/3200
P9	8	DGR362500M/P9/8	TORNILLO DGR2500/3200

VERSION 1.0



MOTOR DGR 3200 REF: DGR363200M

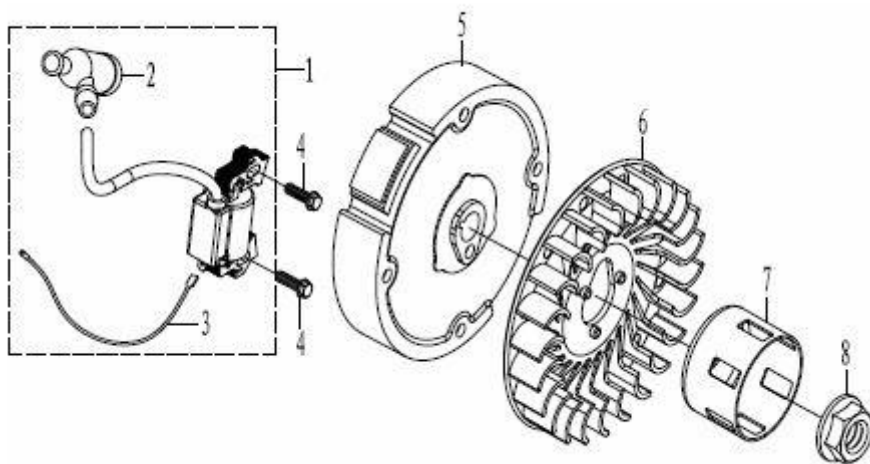

P10

PAG	POS	REFERENCIA	DESCRIPCION
P10	1	DGR362500M/P10/1	BOBINA DE ENCENDIDO DGR2500/3200
P10	2	DGR362500M/P10/2	PIPA BUJIA DGR2500/3200
P10	3	DGR362500M/P10/3	CABLE PARE DGR2500/3200
P10	4	DGR362500M/P10/4	TORNILLO BOBINA DGR2500/3200
P10	5	DGR362500M/P10/5	VOLANTE MAGNETICO DGR2500/3200
P10	6	DGR362500M/P10/6	VENTILADOR DGR2500/3200
P10	7	DGR362500M/P10/7	POLEA ARRANCADOR DGR2500/3200
P10	8	DGR362500M/P10/8	TUERCA VOLANTE DGR2500/3200

VERSION 1.0



MOTOR DGR 3200 REF: DGR363200M

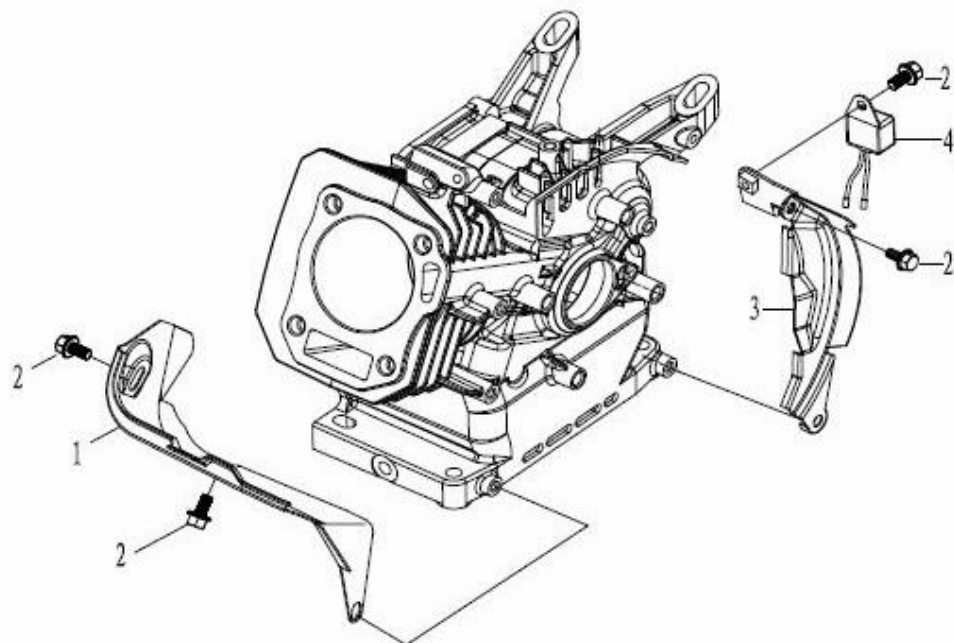

P11

PAG	POS	REFERENCIA	DESCRIPCION
P11	1	DGR362500M/P11/1	CHAPA AIREACION INFERIOR DGR2500/3200
P11	2	DGR362500M/P11/2	TORNILLO CHAPA DGR2500/3200
P11	3	DGR362500M/P11/3	CHAPA AIREACION TRASERA DGR2500/3200
P11	4	DGR362500M/P11/4	DIODO DGR2500/3200

VERSION 1.0